

## DESCRIPTION

The AP72200 is a high current synchronous buck-boost converter providing high efficiency, excellent transient response and high DC output accuracy. The targeted applications are smartphones, tablets, and other handheld devices. The AP72200 utilizes a four-switch H-bridge configuration to support buck and boost operation. The buck-boost provides at least 2A output current.

The current control scheme handles wide input/output voltage ratios and provides low external component count with outstanding performance in line/load transient response

and seamless transition between buck and boost modes.

The AP72200 features I<sup>2</sup>C compatible, 2-wires serial interface consisting of a bidirectional serial-data line, SDA, and a serial-clock line, SCL. It supports SCL clock rates up to 3.4MHz.

The AP72200 also features UVLO, OTP, and OCP to protect the circuit.

This IC is available in a small 2.125 x 1.750mm, 20 balls WLCSP package

## FEATURES

- $V_{IN}$  2.3V to 5.5V
- Output Voltage range: 2.6V to 5.14V
- 2A Continuous Output Current for  $V_{OUT}=3.4V$  and  $V_{IN}>2.9V$   
Efficiency Up to 97%
- 2.5MHz Switching Frequency
- I<sup>2</sup>C Interface
- Selectable MODE PFM/PWM
- Ultrasonic Operation Programmable through I<sup>2</sup>C
- Power Good Indicator with 5M $\Omega$  Internal Pull-up
- Adjustable Overcurrent Limit
- Full Protected for Overcurrent, Short Circuit, Reverse Current Protection, Overtemperature, and UVLO
- **Totally Lead-Free & Fully RoHS Compliant**
- **Halogen and Antimony Free. "Green" Device**

## APPLICATIONS

- Smartphones
- Tablets
- Portable Consumer Devices

## TYPICAL APPLICATIONS CIRCUIT

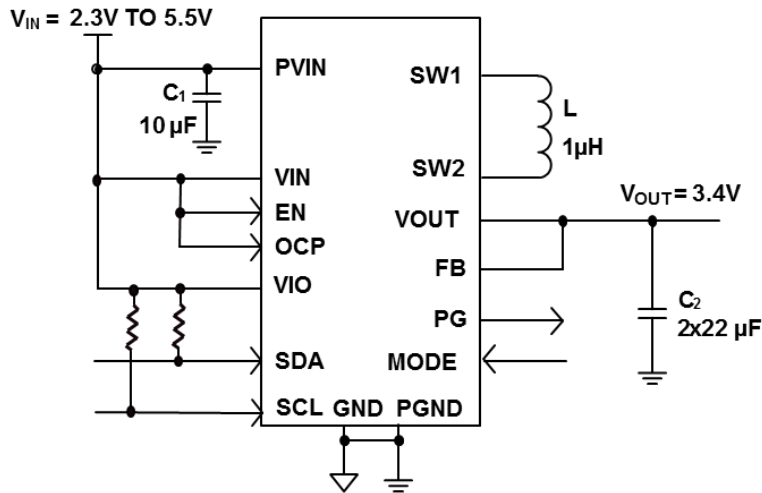

## RECOMMENDED OPERATING CONDITIONS

Symbol	Parameter	Rating	Unit
$V_{IN}, V_{IO}, PV_{IN}$	Supply Voltage	-0.3 to +7.0	V
VOUT	Output Voltage	-0.3 to +6.0	V
$V_{SW1}, V_{SW2}$	Switch Node Voltage	-1.0 to $V_{IN} + 0.3$	V
VIO	I <sup>2</sup> C Voltage	-1.0 to $V_{IN} + 0.3$	V
All other pins		-0.3V to +7.0	V
$T_J$	Junction Temperature	+150	°C
$T_L$	Lead Temperature	+260	°C
<b>ESD Susceptibility</b>			
HBM	Human Body Mode	3000	V
CDM	Device Charged Model	1000	V

## ORDERING INFORMATION

Part Number	Package Code	Package	Identification Code	Tape and Reel	
				Quantity	Part Number Suffix
AP72200CT20-7	W-WLB2118-20	WLCSP-20	D7	3000	-7

## EVALUATION BOARD

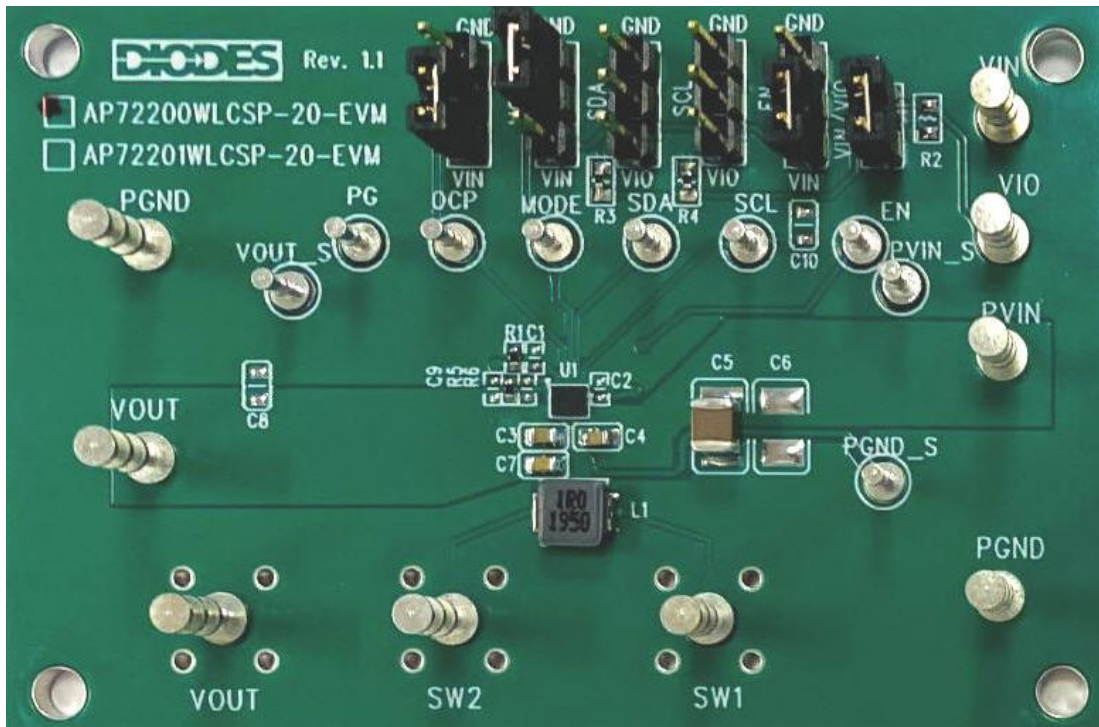

Figure 1. AP72200-EVM

## QUICK START GUIDE

The AP72200 EVM board has a simple layout and allows access to the appropriate signals through test points. To evaluate the performance of the AP72200, follow the procedure below:

1. Insert jumpers to configure the EVM board setting as described in the Application Information sections of the device datasheet.
2. Use MODE switch to set PWM mode (VIN) or SKIP/PFM mode (GND).
3. Use OCP switch to set to 1.8A (GND) or 4.3A (VIN) Peak Overcurrent Threshold.
4. Use EN switch to set device enabled (VIN) or disabled (GND).
5. Use the VIN/VIO switch to connect VIN to VIO.
6. Use the SDA and SCL switch to connect SDA high (VIO) or Low (GND).
7. Connect a 5.0V power supply between the PVIN and PGND terminals. Make sure the

- power supply is turned off.
8. Connect an adjustable current or resistive load to the VOUT and PGND terminals.
  9. Turn on the power supply. Do not turn on the power supply until all connections are completed and fully checked.
  10. The EVB board should now power up with a 3.4V output voltage.
  11. Increase the load current and observe the output voltage change.
  12. Check for the stable operation of the SW1 and SW2 signal on the oscilloscope. Measure the switching frequency on SW1 and SW2 probe jack in the EVB board.
  13. Measure the output ripple on the VOUT probe jack in the EVB board.
  14. Use the I2C to read and write to registers. (as described in the device datasheet)

## MEASUREMENT/PERFORMANCE GUIDELINES:

1. When measuring the output voltage ripple, maintain the shortest possible ground lengths on the oscilloscope probe. Long ground leads can erroneously inject high frequency noise into the measured ripple.
2. When measure the efficiency and load regulation, connect the voltage meter between VOUT\_S and PGND\_S for accurate Kelvin output voltage measurement and between PVIN\_S and PGND\_S for accurate input Kelvin voltage measurement.

## EVALUATION BOARD SCHEMATIC

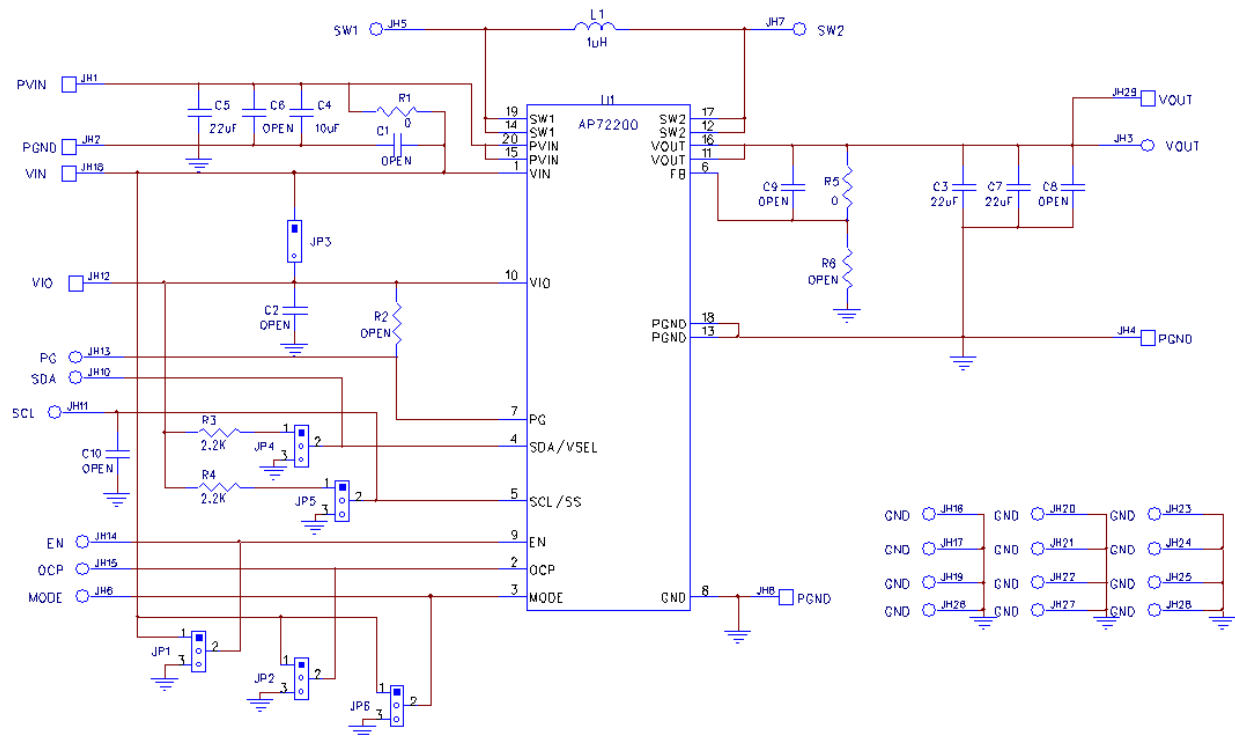
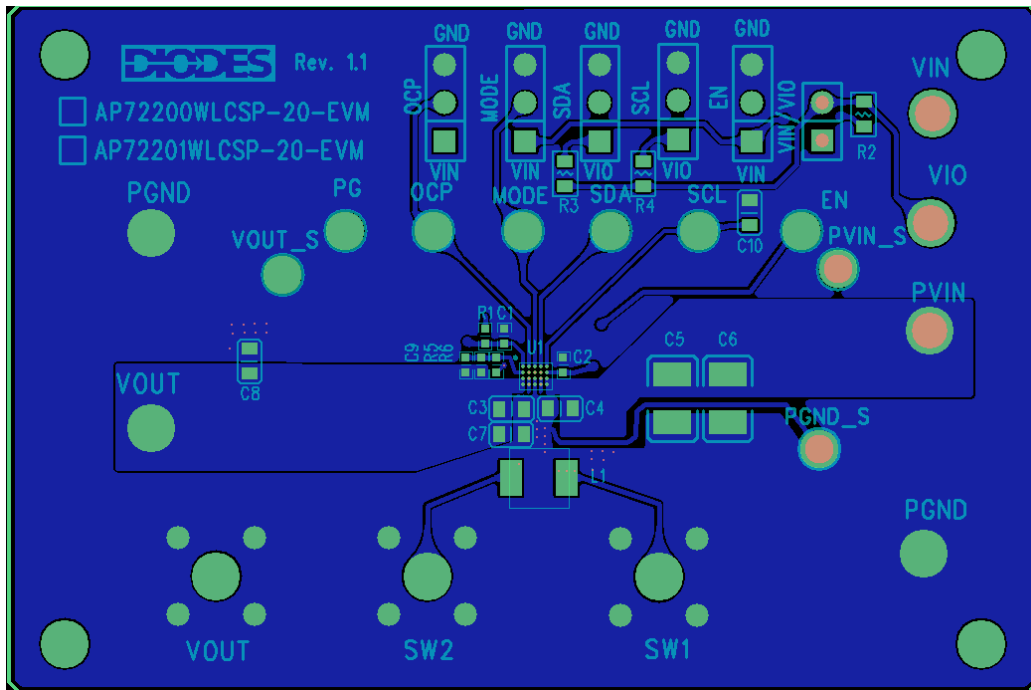
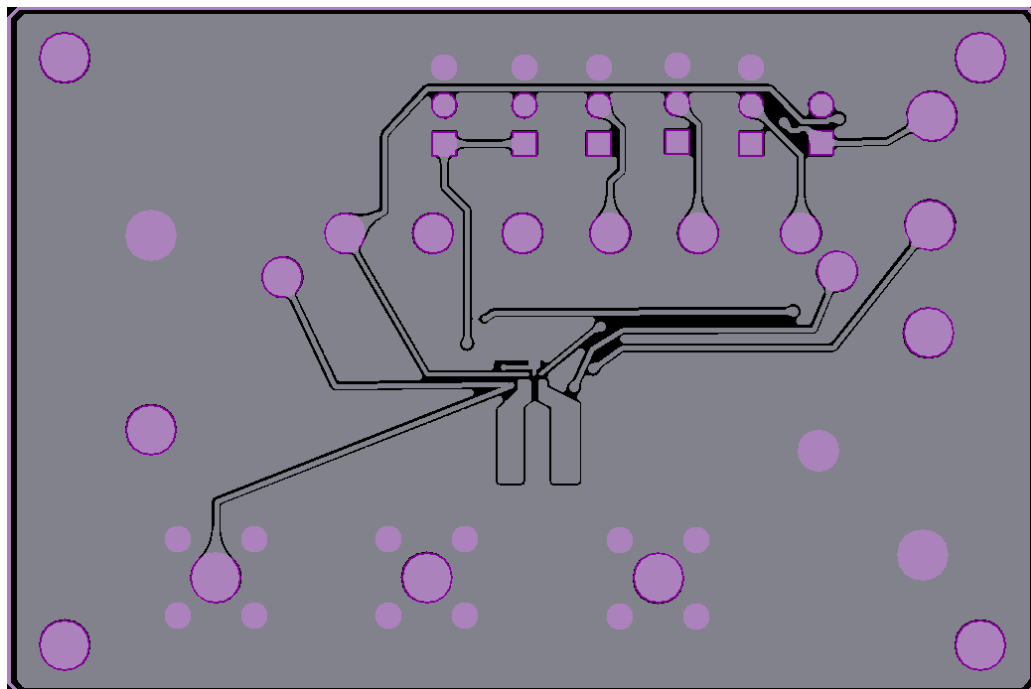

Figure 2. AP72200-EVB Schematics

**PCB LAYOUT**



**Figure 3. AP72200-EVM – Top Layer**



**Figure 4. AP72200-EVM – Bottom Layer**

## BILL OF MATERIALS for AP72200 EVM

Qty	Ref	Value	Description	Package	Vendor	Manufacturer P/N
2	C3, C7	22 $\mu$ F	Ceramic Capacitor, 10V, X5R, 20%	0603	Murata	GRM188R61A226ME15D
1	C4	10 $\mu$ F	Ceramic Capacitor, 6.3V, X5R, 20%	0603	Murata	GRM188R60J106ME47D
1	C5	22 $\mu$ F	Ceramic Capacitor, 25V, X5R	1210	Murata	12103D226KAT2A
2	R1, R5	0 $\Omega$	Film Resistor	0402	Yageo	RC0402JR-070RL
2	R3, R4	2.2k $\Omega$	Film Resistor, 1%	0402	Yageo	RC0402FR-072K2L
1	L1	1 $\mu$ H	DCR=22m $\Omega$ , Isat=9A	4x4x1.8 mm	Würth Electronics	74437324010
1	JP_VIN/VIO		PCB Header, 40 POS	1X2	3M	2340-611TG
5	JP_OCP, JP_MODE, JP_SDA, JP_SCL, JP_EN		PCB Header, 40 POS	1X3	3M	2340-611TG
9	PG, SDA, SCL, EN, OCP, MODE, PVIN_S, VOUT_S, PGND_S		PCB Turret Terminals, 0.082"	0.082"	Keystone Electronics	1573-2
9	VIN, PVIN, VIO, VOUTx2, SW1, SW2, PGNDx2		PCB Turret Terminals, 0.094"	0.094"	Keystone Electronics	1598-2
1	U1		DC-DC Converter	WLP20	Diodes Incorporated (Diodes)	AP72200WLCSP-20

### IMPORTANT NOTICE

1. DIODES INCORPORATED (Diodes) AND ITS SUBSIDIARIES MAKE NO WARRANTY OF ANY KIND, EXPRESS OR IMPLIED, WITH REGARDS TO ANY INFORMATION CONTAINED IN THIS DOCUMENT, INCLUDING, BUT NOT LIMITED TO, THE IMPLIED WARRANTIES OF MERCHANTABILITY, FITNESS FOR A PARTICULAR PURPOSE OR NON-INFRINGEMENT OF THIRD PARTY INTELLECTUAL PROPERTY RIGHTS (AND THEIR EQUIVALENTS UNDER THE LAWS OF ANY JURISDICTION).
2. The Information contained herein is for informational purpose only and is provided only to illustrate the operation of Diodes' products described herein and application examples. Diodes does not assume any liability arising out of the application or use of this document or any product described herein. This document is intended for skilled and technically trained engineering customers and users who design with Diodes' products. Diodes' products may be used to facilitate safety-related applications; however, in all instances customers and users are responsible for (a) selecting the appropriate Diodes products for their applications, (b) evaluating the suitability of Diodes' products for their intended applications, (c) ensuring their applications, which incorporate Diodes' products, comply the applicable legal and regulatory requirements as well as safety and functional-safety related standards, and (d) ensuring they design with appropriate safeguards (including testing, validation, quality control techniques, redundancy, malfunction prevention, and appropriate treatment for aging degradation) to minimize the risks associated with their applications.
3. Diodes assumes no liability for any application-related information, support, assistance or feedback that may be provided by Diodes from time to time. Any customer or user of this document or products described herein will assume all risks and liabilities associated with such use, and will hold Diodes and all companies whose products are represented herein or on Diodes' websites, harmless against all damages and liabilities.
4. Products described herein may be covered by one or more United States, international or foreign patents and pending patent applications. Product names and markings noted herein may also be covered by one or more United States, international or foreign trademarks and trademark applications. Diodes does not convey any license under any of its intellectual property rights or the rights of any third parties (including third parties whose products and services may be described in this document or on Diodes' website) under this document.
5. Diodes' products are provided subject to Diodes' Standard Terms and Conditions of Sale (<https://www.diodes.com/about/company/terms-and-conditions/terms-and-conditions-of-sales/>) or other applicable terms. This document does not alter or expand the applicable warranties provided by Diodes. Diodes does not warrant or accept any liability whatsoever in respect of any products purchased through unauthorized sales channel.
6. Diodes' products and technology may not be used for or incorporated into any products or systems whose manufacture, use or sale is prohibited under any applicable laws and regulations. Should customers or users use Diodes' products in contravention of any applicable laws or regulations, or for any unintended or unauthorized application, customers and users will (a) be solely responsible for any damages, losses or penalties arising in connection therewith or as a result thereof, and (b) indemnify and hold Diodes and its representatives and agents harmless against any and all claims, damages, expenses, and attorney fees arising out of, directly or indirectly, any claim relating to any noncompliance with the applicable laws and regulations, as well as any unintended or unauthorized application.
7. While efforts have been made to ensure the information contained in this document is accurate, complete and current, it may contain technical inaccuracies, omissions and typographical errors. Diodes does not warrant that information contained in this document is error-free and Diodes is under no obligation to update or otherwise correct this information. Notwithstanding the foregoing, Diodes reserves the right to make modifications, enhancements, improvements, corrections or other changes without further notice to this document and any product described herein. This document is written in English but may be translated into multiple languages for reference. Only the English version of this document is the final and determinative format released by Diodes.
8. Any unauthorized copying, modification, distribution, transmission, display or other use of this document (or any portion hereof) is prohibited. Diodes assumes no responsibility for any losses incurred by the customers or users or any third parties arising from any such unauthorized use.
9. This Notice may be periodically updated with the most recent version available at <https://www.diodes.com/about/company/terms-and-conditions/important-notice>

The Diodes logo is a registered trademark of Diodes Incorporated in the United States and other countries.  
All other trademarks are the property of their respective owners.  
© 2024 Diodes Incorporated. All Rights Reserved.

[www.diodes.com](http://www.diodes.com)