

# The Use of Zetex E-Line Transistors in Motor and Solenoid Functions within Printers

Effective Logic to High Current Load Interfacing

Neil Chadderton

## Introduction

The majority of modern printers use stepper motors and solenoids for driving the various transport and print mechanisms. These applications usually involve using drive signals directly from the control logic; and handling high-pulsed currents and voltages. In the past this has led to TO220 and similar devices being used, but an alternative is now available. Devices from the Super E-Line range of transistors are direct replacements for the aforementioned devices in medium power situations. This Application Note outlines a few examples that are applicable and is by no means comprehensive.

## Motor Drivers

Stepper motors are used for many printer functions, such as platten roller and print head position drivers, and daisy wheel drivers.

A typical circuit used in many printers is shown conceptually in Figure 1. The driver transistors Q1-Q4 are switched in an ordered sequence to energise the motor's coils to produce the desired action. As the transistor load is inductive, the voltage present on switching off easily exceeds the supply

voltage, while the current flowing in the on-state follows a ramp-like appearance.

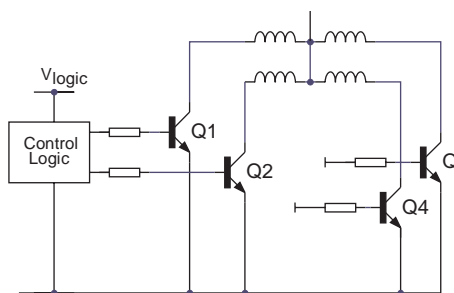

**Figure 1**  
**Typical Stepper Motor Drive Circuit**  
**(diagrammatic).**

These conditions are illustrated in Figure 2, which shows the voltage and current experienced by the transistor in a typical cycle. (In this case, a centre drain MOSFET, the ZVN4206C has been employed).

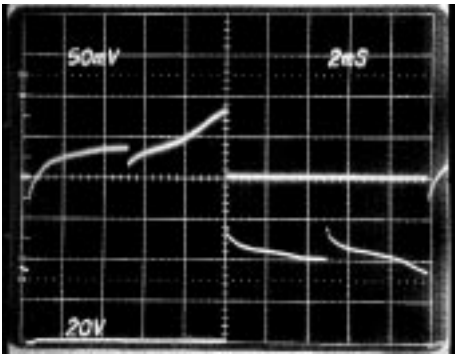

**Figure 2**  
**Typical Waveforms on a 4-Phase Stepper Motor Driver Transistor (ZVN4206C).**  
**Upper Trace: Collector Current - 0.5A/div.**  
**Lower Trace: Collector Voltage - 20V/div. (26V supply)**

For circuit simplicity and ease of driving, Darlington devices are a favourite in this application, but a consequence of driving inductive loads such as these is the need to protect the device from negative current pulses. In many of the expensively packaged Darlington transistors, this is effected by an integral collector-emitter diode.

An alternative is to use MOSFET transistors, which exhibit all the electrical requirements in a smaller package and at much reduced cost, and possess the necessary protection diode due to the inherent nature of MOSFET technology.

Even in very demanding driving applications for larger printer motors such as illustrated in Figure 3, E-Line transistors can be used to obtain a large cost advantage.

The negative current pulses due to the driving configuration, and the high current involved (greater than 3A), make this an ideal situation for a high performance E-Line Darlington transistor. Used with an inexpensive externally-wired diode, this offers up to a four-times cost-saving on the expensive TO220 alternative.

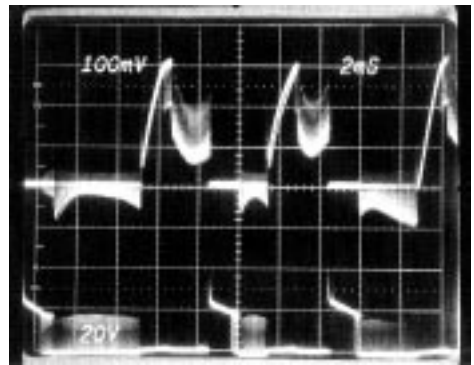
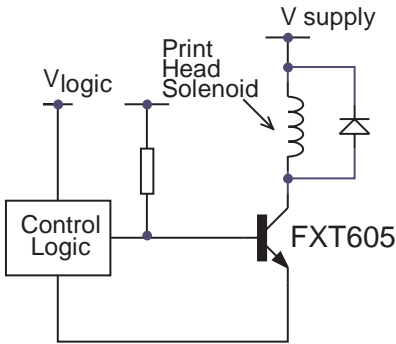

**Figure 3**  
**Waveforms on Stepper Motor Driver Transistor for a Large Printer (FXT605).**  
**Upper Trace: Collector Current - 1A/div.**  
**Lower Trace: 20V/div.**

## Dot Matrix Head Drivers

For the dot matrix form of printer, solenoids are usually used to force a pin to strike the ribbon and thereby produce a dot on the paper. A column of these pins is driven as required to match the matrix representation of printable characters.

As in the motor driver example, the solenoid also presents an inductive load and Figure 4 typifies the circuit used to drive it. A control pulse from the logic turns the transistor on to energise the solenoid coil.



**Figure 4**  
Typical Circuit of a Dot Matrix Head Driver.

The waveforms shown in Figure 5 were obtained for a dot matrix head driver. The back-emf and the high current peaks demand a device of superior performance easily met by the Zetex range of E-Line devices.

### Centre Collector E-line Transistors

Zetex Semiconductors offer a comprehensive range of centre collector E-Line transistors that can directly replace TO220 and similar devices in many applications. These devices match all the electrical requirements, and also show a large saving in size and cost.

## Appendix A

### FXT605 Centre Collector NPN Power Darlington Transistor

SYMBOL	MIN.	MAX.	UNIT	CONDITIONS.
$I_C$		1	A	Continuous
$I_{CM}$		4	A	Pulsed
$V_{(BR)CEO}$	120		V	$I_C=10mA, I_B=0$
$V_{CE(sat)}$		1.0 1.5	V V	$I_C=0.25A, I_B=0.25mA$ $I_C=1A, I_B=1mA$
$h_{FE}$	2000 500			$I_C=50mA, V_{CE}=5V$ $I_C=2A, V_{CE}=5V$
$f_T$	150		MHz	$I_C=100mA, V_{CE}=10V f=20MHz$

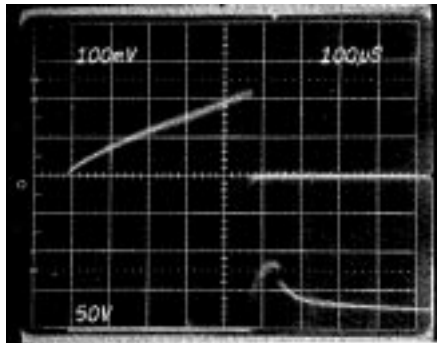

**Figure 5**  
Waveforms on a Dot Matrix Head Driver Transistor (FXT605).  
Upper trace: 1A/div. Lower trace: 50V/div.

## Summary

Zetex transistors can be used with confidence in many motor and solenoid driver applications of which the above are examples. The state of the art transistor technology coupled with the excellent thermal characteristics of the E-Line package, and the convenience of the centre collector option, produce an attractive solution to an otherwise costly situation.

## Appendix B

### ZVN4206C N-Channel Enhancement Mode Vertical DMOS FET

#### ABSOLUTE MAXIMUM RATINGS

PARAMETER	SYMBOL	VALUE	UNIT
Drain-Source Voltage	$V_{DS}$	60	V
Continuous Drain Current at $T_{amb}=25^{\circ}C$	$I_D$	600	mA
Pulsed Drain Current	$I_{DM}$	8	A
Gate-Source Voltage	$V_{GS}$	$\pm 20$	V
Power Dissipation at $T_{amb}=25^{\circ}C$	$P_{tot}$	0.7	W
Operating and Storage Temperature Range	$T_j; T_{stg}$	-55 to +150	$^{\circ}C$

#### ELECTRICAL CHARACTERISTICS (at $T_{amb} = 25^{\circ}C$ unless otherwise stated).

PARAMETER	SYMBOL	MIN.	MAX.	UNIT	CONDITIONS.
Drain-Source Breakdown Voltage	$BV_{DSS}$	60		V	$I_D=1mA, V_{GS}=0V$
Gate-Source Threshold Voltage	$V_{GS(th)}$	1.3	3	V	$I_D=1mA, V_{DS}=V_{GS}$
Gate-Body Leakage	$I_{GSS}$		100	nA	$V_{GS}=\pm 20V, V_{DS}=0V$
Zero Gate Voltage Drain Current	$I_{DSS}$		10 100	$\mu A$ $\mu A$	$V_{DS}=60V, V_{GS}=0V$ $V_{DS}=48V, V_{GS}=0V, T=125^{\circ}C(2)$
On-State Drain Current(1)	$I_{D(on)}$	3		A	$V_{DS}=25V, V_{GS}=10V$
Static Drain-Source On-State Resistance (1)	$R_{DS(on)}$		1 1.5	$\Omega$ $\Omega$	$V_{GS}=10V, I_D=1.5A$ $V_{GS}=5V, I_D=500mA$
Forward Transconductance(1)(2)	$g_{fs}$	300		mS	$V_{DS}=25V, I_D=1.5A$
Input Capacitance (2)	$C_{iss}$		100	pF	$V_{DS}=25V, V_{GS}=0V, f=1MHz$
Common Source Output Capacitance (2)	$C_{oss}$		60	pF	
Reverse Transfer Capacitance (2)	$C_{rss}$		20	pF	

Both Appendix A and B are extracts from the *Discrete Through Hole Components Data Book* which detail full characterisation of the products quoted.